

Model SF-1000

Certified 1000 Gallons • Standard Flow (.75 gpm)

*This system was evaluated to a test capacity of 2000 gallons, 200% of the rated capacity of 1000 gallons, to allow for a considerable safety margin.

Drinking Water System for your home and family

5 Stage Exclusive Standard flow Design Exclusive Quick Change Cartridge

Stage 1: Built-in Pre-Filter

Filters 5 micron for dirt / sediment/filterable iron etc.

Stage 2: Fine Filtration

.5 Micron (1/50,000 of an inch) for reduction of color, turbidity, lead, protozan cysts and other particulates including filterable iron.

Stage 3: Adsorption

Specially formulated High Capacity carbon with over **600,000 square meters** of adsorption surface area for superior chemical reduction, dissolved lead, taste, odor caused from chlorine.

Stage 4: Filter Protection Silver Zeolite technology blended throughout the filter using Ion exchange to "Manage" the silver release giving optimum efficacy and longevity.

EPA Registered, FDA listed and NSF-certified for food and water uses.



Stage 5: Scale Control*

Polyphosphate spheres slow release provides protection against hard water scale for water using appliances.

Replacement cartridge PN# RC-SF-1000

For conditions of use, health claims certified by California Department of Public Health, and replacement parts, see the performance data sheet.

California Department of Public Health
Certification Number 081927

*Claim not certified

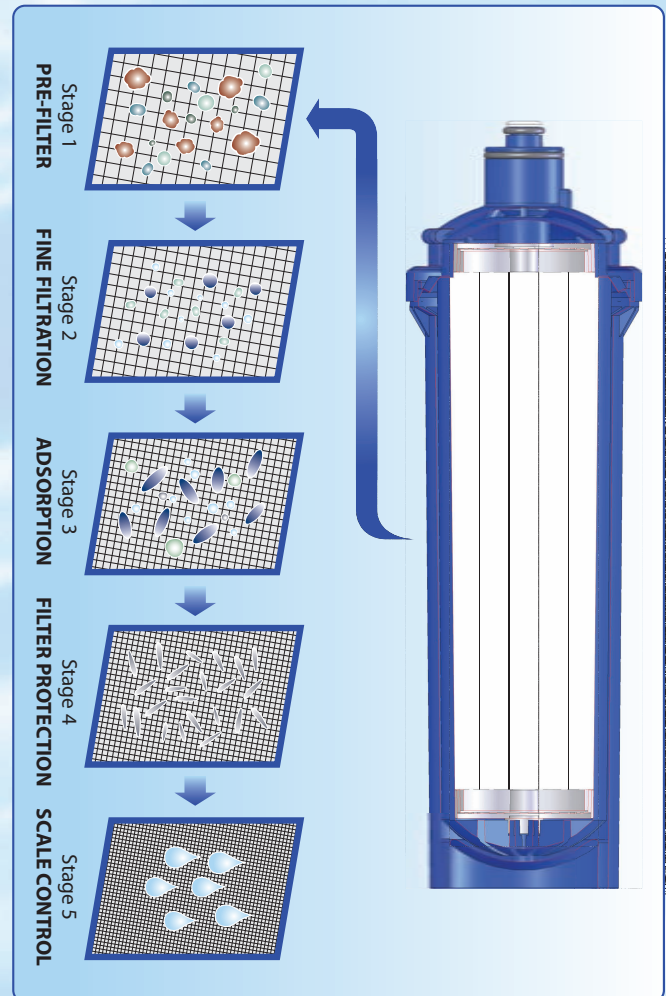

The SF-1000 Standard Flow system will provide delicious tasting, healthful, crystal clear water from the dispensing tap of your choice. It is recommend to use a separate dispensing tap when installed at a kitchen sink location. Great installation for the bath/bar sink cold side of faucet. Your family will now enjoy the benefits of Alwaysfresh Water the way you want it for drinking, cooking, hot or cold beverages, rinsing fruits and vegetables, as well as, producing filtered Ice.

The Standard flow rate coupled with the high gallonage capacity allows you to use one system for Filtering your refrigerator's ice/water dispenser, instant hot tap, under-sink chiller, and built-in coffee maker... All with one system.

Use this system to fill reusable sports bottles to protect our environment by reducing solid waste and oil usage to produce and transport these throw away bottles.

Use this system when Volatile Organic Chemicals (VOC's) are not a primary concern, or for alternate low usage area in the home. For example, master bath, recreational areas, bar sink etc.

Remember that 80% of drinking, cooking, and food preparation water is used at the kitchen sink location. Of course if VOC's or MTBE are a concern select the HFC-1000 product.

ALWAYSfresh[®]
Water the way you want it[®]

©2009 Waterline Technology[®]

Protected under patents 6,695,891, 6,926,826, 6,977,006, 7,172,693, 7,476,314
and other Patents Pending
Manufactured in the USA

Model SF-1000

Certified 1000 Gallons • Standard Flow (.75 gpm)



www.reducebottledwaterwaste.com

Drinking Water System for your home and family

Certified Performance

This system conforms to NSF/ANSI 42 and 53 for specific performance claims as verified and substantiated by test data:

Standard 42: Aesthetic Effects

Chemical Unit
Taste and Odor Reduction and Aesthetic Chlorine Reduction
Mechanical Filtration Unit
Particulate Reduction Class 1
96.7% reduction of particles .5 micron and larger in size

Standard 53: Health Effects

Chemical Reduction Unit
Lead Reduction

Mechanical Filtration Unit

Turbidity Reduction
Cyst Reduction



Operating Specifications

Min/Max working pressure:

10 psi (0.7 bar)/125 psi (8.6 bar), nonshock

Temperature: 35-100° F (2-38° C)

Service flow rate .75 gpm (2.85 Lpm)

Rated Service Capacity: 1000 gallons (3800 L)

Product performance is dependent upon incoming water conditions. Do not use with water that is microbiologically unsafe or of unknown quality without adequate disinfection before or after the system. Systems certified for cyst reduction may be used on disinfected waters that may contain filterable cysts.

The contaminants or other substances removed or reduced by this water filter device are not necessarily in your water.

Warranty:

12 months from date of purchase or
24 months from date of manufacture.
See warranty sheet for details

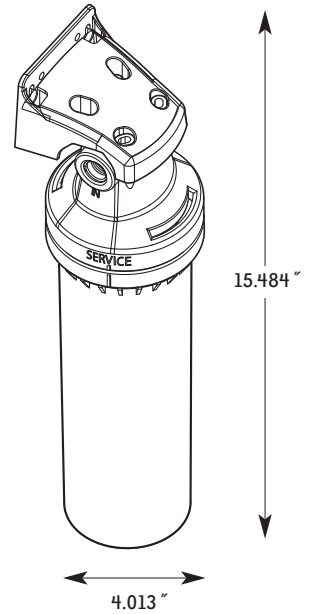

Typical Installation Options:

Existing Cold Faucet Installation with Existing Cold Sink Faucet Filtered

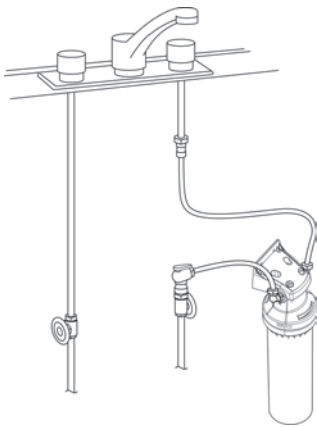

Undersink Separate Faucet Installation; Existing Cold Sink Faucet Non-Filtered

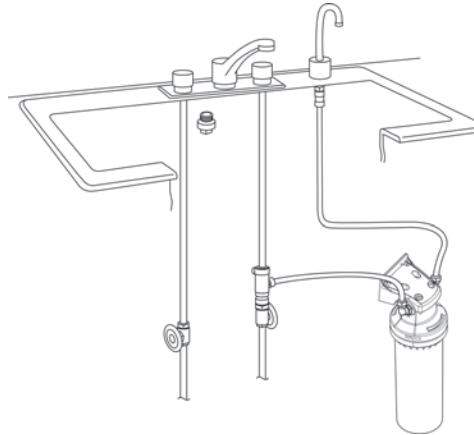

Note: Separate faucet recommended for installation at kitchen sink

Companion Products:



Alwaysfresh™
Brewer coffee or tea



Alwaysfresh™
Instant Hot



Alwaysfresh™ Filtered hot
and cold water
Water the way you want it™



Alwaysfresh™
Chiller



Alwaysfresh™
Dispensing Faucet's



Waterline Technology®
961 N. Main St., Ste 102 • P.O. Box 396
Mansfield, OH 44903

Phone: 419-529-3949 • Technical Service: 1-800-522-3949
Fax: 419-529-8484 • www.alwaysfreshh2o.com